

Self-Mailing

easy and efficient



Flexi Plus

Seal securely instead of inserting

The Flexi Plus Sealer is the ideal system for preparing printed documents for mailing without inserting. The high-capacity self-mailer folds and seals paper by a clever process, making envelopes and glue unnecessary: Whether standard copy paper, coated, glue- or chemically coated paper – the document is heated and safely sealed under pressure. A clean, reliable and economical solution and thanks to the simple modular design, with the added value of low service and maintenance costs.

At up to 12,500 documents per hour Flexi Plus delivers high production capacity. The unique closing technology seals the document with heat and pressure and is perfectly suitable for sensitive data such as PIN codes, bank statements, insurance information or direct mailings. The Flexi Plus Sealer makes self-mailing easy and efficient, additionally offering a wide range of possibilities.

› Bigger sheet-feeder for up to 1,500 sheets optional

- › The modular system can be configured for continuous forms at any time
- › Four folding pockets permit single, letter, Z or double fold
- › Symmetrical or asymmetrical fold
- › Feeder for an enclosure in A6 format optional upon request
- › Seals different types of paper with heat and pressure – even expired glue-coated documents

- › Toner sealing requires no special paper; toner frames are printed together with the text in one step
- › Easily comprehensible operation reduces training requirements
- › Easy accessibility as well as simple and cost-effective maintenance even without service specialists
- › Low TCO (Total Cost of Ownership) thanks to attractive purchase price and low maintenance requirements

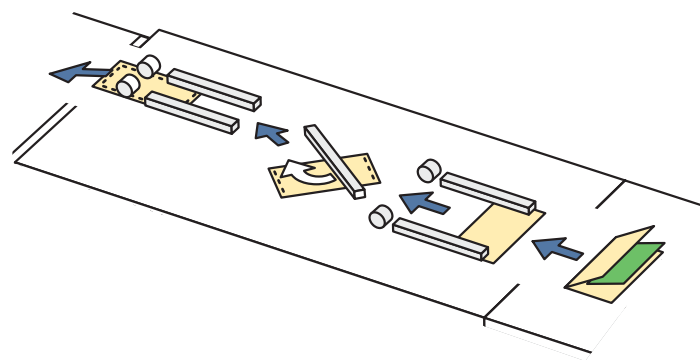

Technical Data

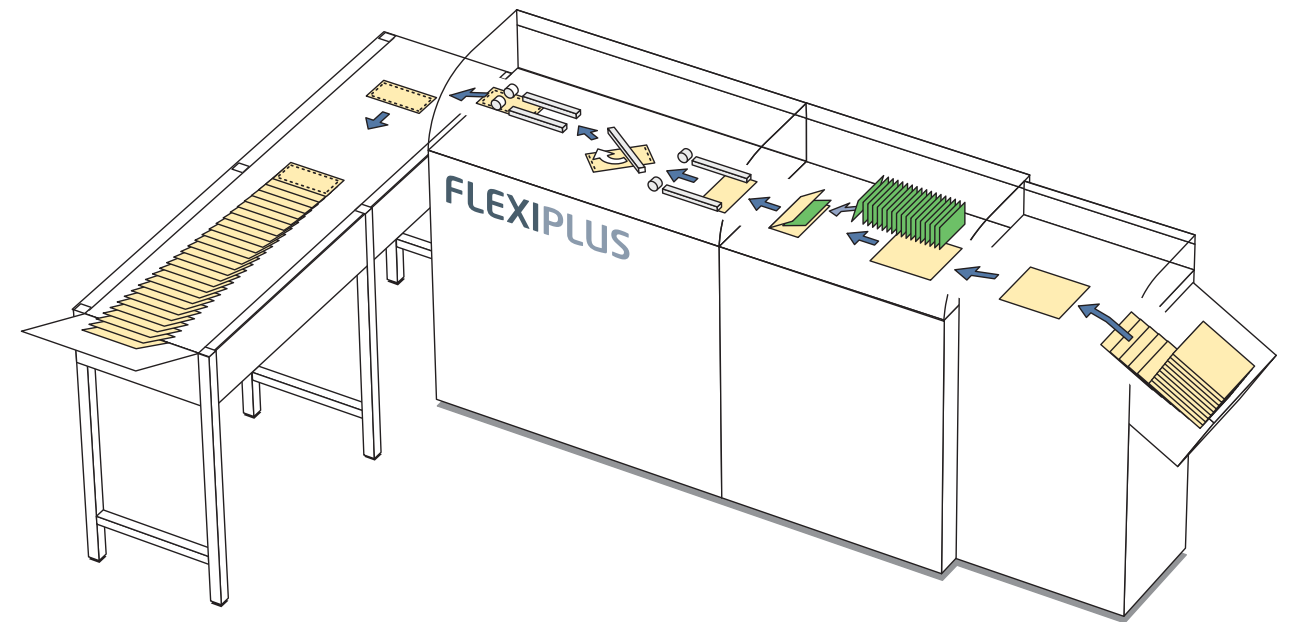

Max. performance

Without enclosure	up to 12,500 sheets/h	With enclosure	up to 6,250 sheets/h
-------------------	-----------------------	----------------	----------------------

Standard paper formats

Width	205 mm - 230 mm	Paper weight	70 - 140 g/m ²
Height	11" - 14"	Other formats and paper weights upon request	

Paper quality

Standard copy paper	Glue-/chemically coated paper
Coated paper	

Standard features

Infeed and upright unit	Four pocket folding unit
4 cassettes with upper and lower heaters	4 pressure wheels
4 fully adjustable perforation knives	Microprocessor controlled
Conveyor stacker	Batch and total counter

Options

Cut-sheet feeder up to 1,500 sheets	Enclosure station (A6, 4 1/7" x 5 5/6")
2D or barcode reader at input or output	Unistacker (1,880 mm + 1,100 mm extension module)

Sealight

Self-mailing with minimum space

The self-mailer Sealight is very easy to operate and offers an excellent price performance ratio. Processing up to 2,500 documents per hour, this compact sealer is perfect for handling small and mid-sized batches. Sealight is a highly flexible system, which can be configured to meet individual needs. The ability to seal documents securely through heat and pressure with optional perforation, make Sealight the ideal solution for sending sensitive contents. Low TCO with easy servicing and limited maintenance expenses make Sealight an attractive self-mailing solution.

Processing up to 2,500 documents per hour, Sealight is perfect for handling small and mid-sized batches. It also offers a wide variety of opportunities.

› Cut-sheet processing

› Optional connection to a printer

› Two folding pockets for single, C and Z fold

› Seals different types of paper through heat and pressure

› Perforation cutter available

› Efficient toner sealing

› Easy to use, low maintenance cost

› Optimized TCO

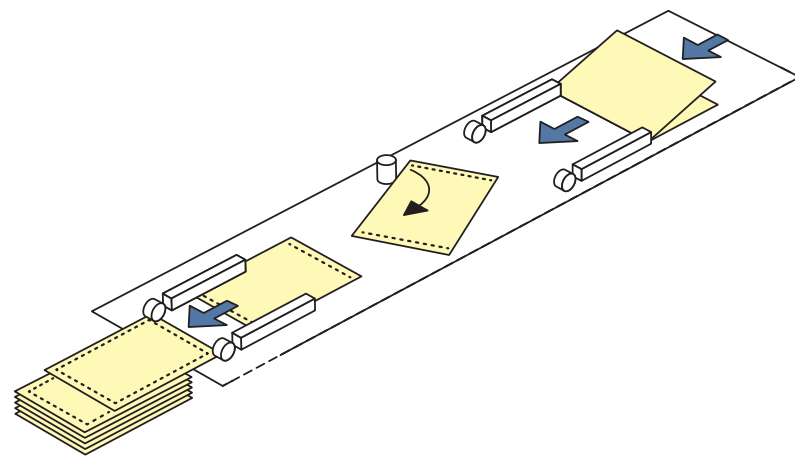

Technical Data

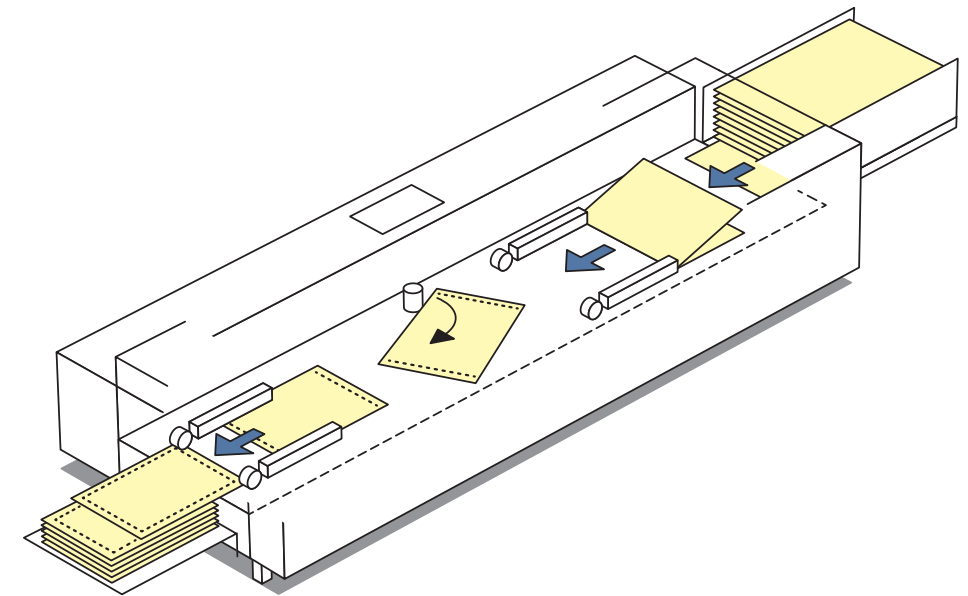

Max. performance

up to 2,500 sheets/h

Standard paper formats

Width	205 mm - 230 mm	Paper weight	70 - 140 g/m ²
Length	8" - 12"	Other formats available upon request	

Paper quality

Standard copy paper	Glue-/chemically coated paper
Coated paper	

Standard specifications

Cut-sheet feeder for up to 50 sheets	4 pressure wheels
Two pocket folding unit	Jam detection
4 lower heaters	

Options

Online connection to printer	Counter
2D or barcode reader	Conveyor stacker
4 upper heaters	Floor stand
Teflon coated heaters	Burster or cutter for continuous processing
Perforation cutter	

Print2Seal

For customized mailings

Print2Seal is the perfect self-mailing solution for businesses looking for flexible and sustainable ways to independently customize their mailings. As an affordable solution for any office, Print2Seal offers an extra distinguishing feature as it can be linked to a standard laser printer, which opens up new opportunities in direct marketing. With a throughput of up to 3,000 documents per hour (single sided print), Print2Seal processes customized information material, flyers or quotes within seconds, from printing to folding and safely sealing.

Print2Seal can process up to 3,000 documents per hour, enabling any office to produce customized mailings easy and efficiently.

› Duplex online printing at a speed of up to 1,800 documents per hour

› Printer integration for customized mailings available

› Perfect for small volumes

› Two pocket folding unit for single and C fold

› Sealing and perforation on the short sides of the document

› Simple handling and quick amortization

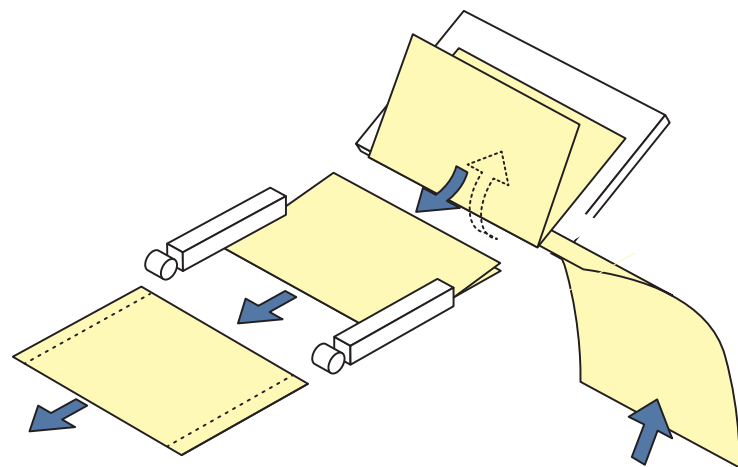

Technical Data

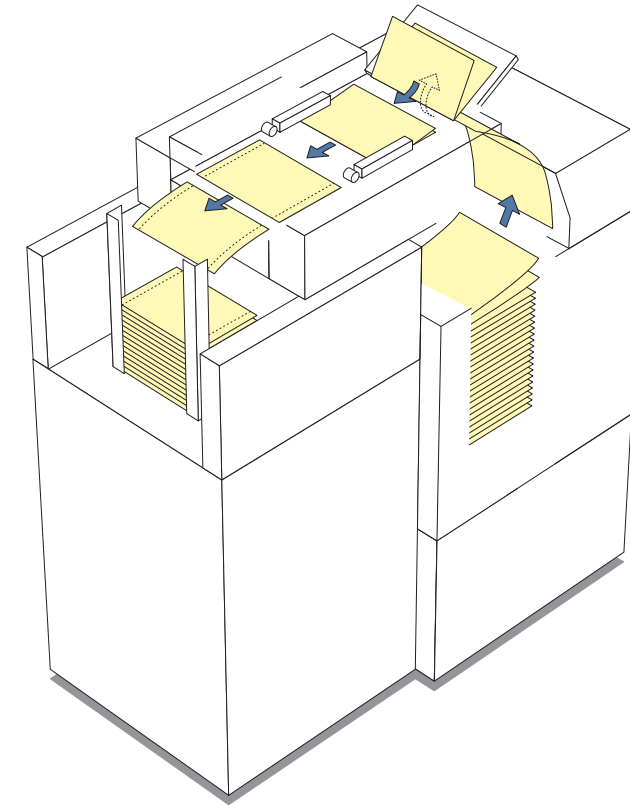

Max. performance

Single sided print	up to 3,000 sheets/h	Duplex print	up to 1,800 sheets/h
--------------------	----------------------	--------------	----------------------

Standard paper formats

Width	A4/US letter	Paper weight	70 - 140 g/m ²
Length	A4/US letter		

Paper quality

Standard copy paper	Glue-/chemically coated paper
Coated paper	

Standard specifications

Two pocket folding unit	Floor stand
Perforation on both of the short sides after folding	

Options

Laser printer with cut-sheet feeder	Batch counter
2D or barcode reader	Cover to protect connection between printer and self-mailer